

## Operating & Installation Guidelines Solimar Aeration Fluidisers



### Guidance (1 of 3)

#### Applications

The silo fluidiser is designed for assisting the flow of dry powdered products in flat or conical silos and hoppers. For standard units, the installation should be PH neutral and temperature should be less than 170°C. The fluidisers work best when the product moisture content is less than 12-15%. As the material becomes wet or sticky, aeration performance will drop quickly.

Large particles such as gravel, feed, grain, and pellets do not aerate. The fluidisers also do not work well in applications where the particles are interlocking such as wood shavings, shredded plastic or fiberglass. Return the Installation Questionnaire for our recommendations for fluidiser use in your specific application.

#### Placement guidelines

Aerate the bottom third or half of the outlet cone. Slope of the cone should be at least 45° for maximum effectiveness.

All standard Solimar products require a cone diameter at point of mounting of 400mm to ensure proper sealing. The Solimar mini fluidiser requires the diameter at point of mounting to be 100mm or greater.

Locate the first row of fluidisers 300mm - 450mm from the discharge opening. There should be enough units to space every 500mm - 600mm on this row.

Subsequent rows should alternate to achieve complete coverage. Spacing on higher rows can be increased.

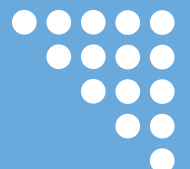
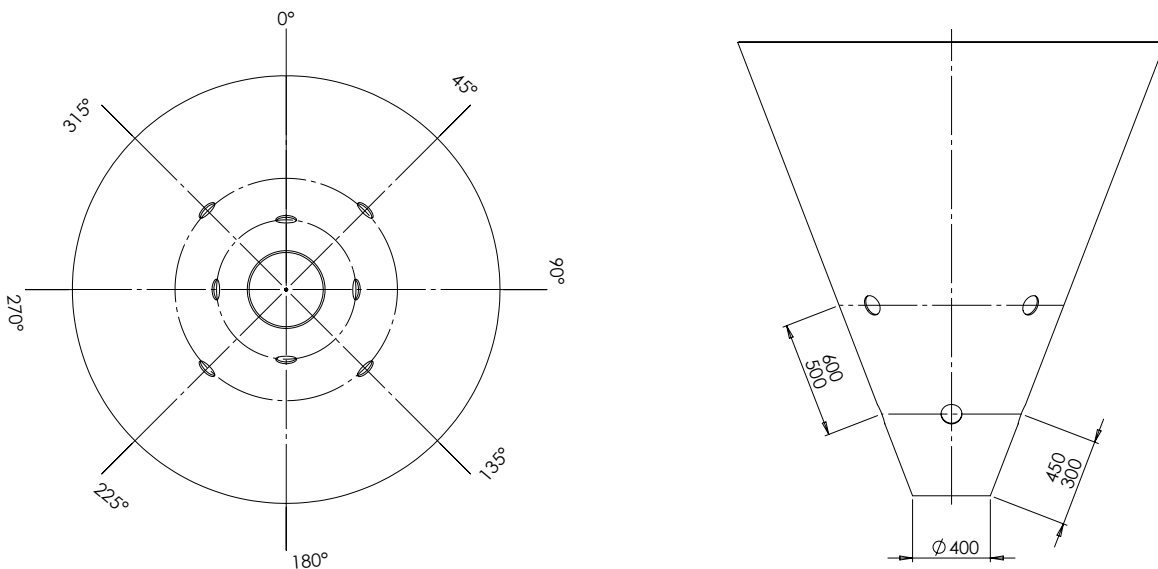

## Operating & Installation Guidelines Solimar Aeration Fluidisers

### Guidance (2 of 3)

#### Air distribution

Only operate the fluidisers while discharging material from the silo to avoid creating air channels or voids. To ensure balanced air distribution it is recommended to use an air manifold or operate no more than four fluidisers together as shown:

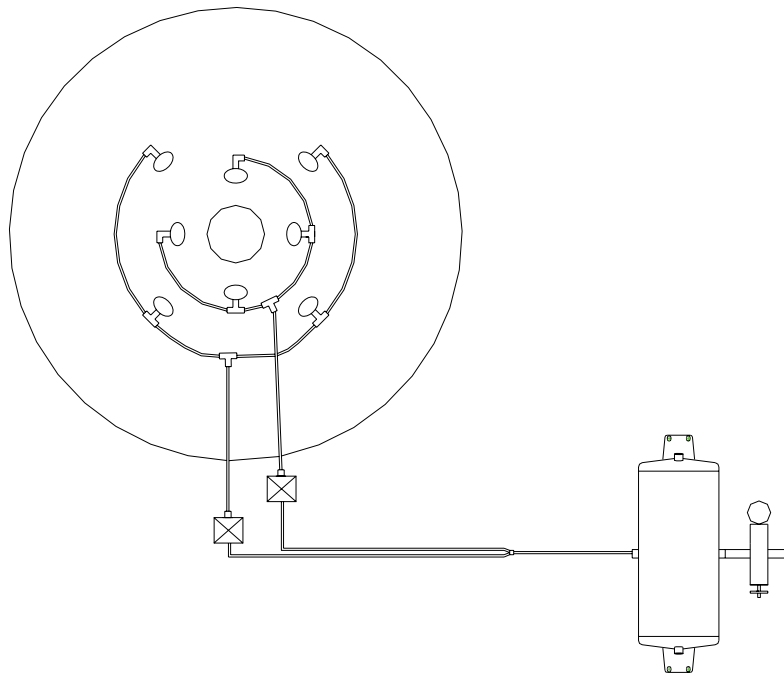

The diagram above is a common configuration showing an air tank fed by an air supply which includes a regulator. Two sets of four fluidisers are piped together using elbow and tee fittings, and the two groups are fed by two solenoid valves coming from the air tank. The recommendation for the air line sizes are as follows:

Fluidiser Series	Airline Options
4300	10mm - 12mm
4400	13mm - 19mm
4500	19mm - 25mm
4800	6mm

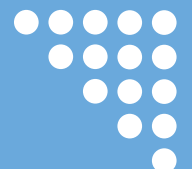

## Operating & Installation Guidelines Solimar Aeration Fluidisers



### Guidance (3 of 3)

#### Air requirements

Air capacity for the different models is shown below:

Series	Airflow Requirements
4300	Capacity 10 - 20 CFM @ 20 - 30 PSI (15 - 30 m <sup>3</sup> /h @ 1 - 2 bar)
4400	Capacity 25 - 40 CFM @ 10 - 20 PSI (40 - 70 m <sup>3</sup> /h @ 0.7 - 1.5 bar)
4500	Capacity 30 - 50 CFM @ 5 - 10 PSI (50 - 85 m <sup>3</sup> /h @ 0.3 - 0.7 bar)
4800	Capacity 2 - 3 CFM @ 20 - 30 PSI (3.5 - 5 m <sup>3</sup> /h @ 1 - 2 bar)

#### Air consumption

Solimar recommend that the fluidisers are not used continuously and are pulsed on and off during the discharging cycle. Pulsed air flow saves air and decreases the chance of air pockets and channeling. Every product and application is unique, but typical pulse sequencing is 2-3 seconds on with a 7-10 second off time. Air consumption required for your application can then be calculated by the following:

$$\text{CFM per fluidiser} \times \text{No. of fluidisers per group} \times \text{No. of groups} \times \frac{\text{Seconds on per group per minute}}{60 \text{ seconds}} = \text{Total CFM}$$

#### Worked example:

$$25 \text{ CFM per fluidiser} \times 4 \text{ fluidisers per group} \times 2 \text{ groups} \times \frac{15 \text{ seconds on per group per minute}}{60 \text{ seconds}} = 50 \text{ CFM}$$

Running this cycle for one minute therefore requires 50 cubic feet of air. If you were to run this cycle over a 2 minute discharge window then 100 cubic feet of air would be required in total. If you were to run this 60 second cycle for 1 minute out of every 5 minutes the average CFM required would therefore be 10 CFM. We can depict this visually as below.

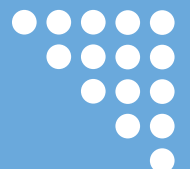
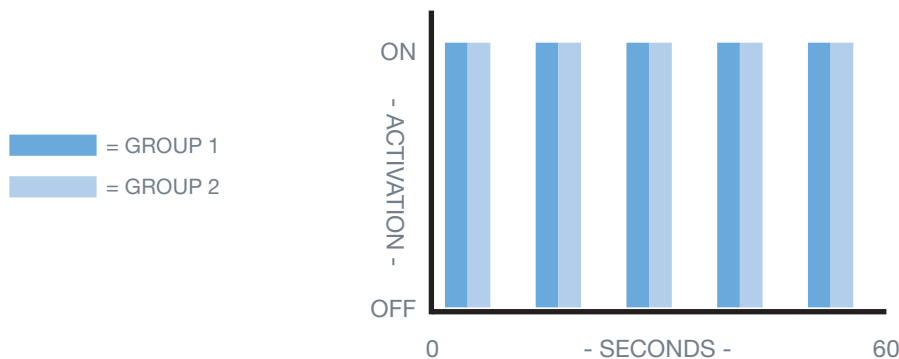

## Operating & Installation Guidelines Solimar Aeration Fluidisers



### Installation: Method 1. No Installation Accessories

1. Drill appropriate size hole in silo wall.

Fluidiser Series	Hole Diameter
4300	22mm
4400	27mm
4500	35mm
4800	13mm

2. Deburr inside and outside of hole. If not deburred, damage to O-ring will occur. Make sure the area where the fluidiser will be mounted is free of debris or defects like dents, caked material, weld seams, etc.

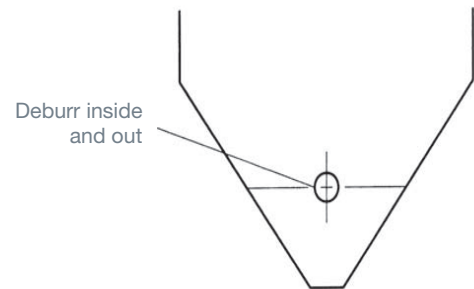

3. From the inside of the silo, have one person insert disk and stem assembly into the hole.
4. From the outside of the silo, have a second person put the flat washer and nut onto the stem.
5. Torque nut to approximately 35Nm or 27Nm for the 4800 series.

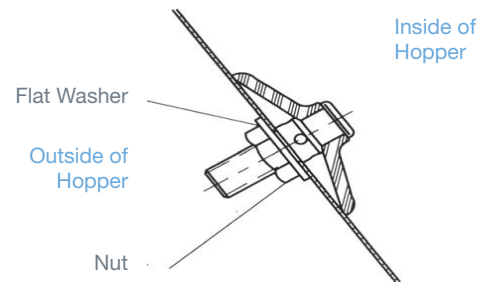

6. Attach air supply line to the stem.

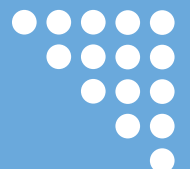
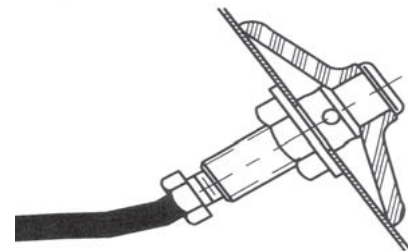

# ProSpare

Make it better.

## Operating & Installation Guidelines Solimar Aeration Fluidisers



### Installation: Method 2. Fast-Fit Kit

1. 4300 Series: Drill a 50mm hole at the fluidiser mounting location.  
Mini fluidiser: Drill a 29mm hole at the fluidiser mounting location.
2. De-burr the inside and outside of the hole.
3. Thread the screw and retaining cable into the fluidiser and tighten to finger tightness only. The thread is compatible with both 1/4" BSP and 1/4" NPT.
4. Fold & Insert the fluidiser disk into the installation hole.
5. Slide the Fast-Fit alignment plate over the retaining cable and into the bin with the recess positioned outward to engage with the hole in the silo wall. Centre the alignment plate in the mounting hole, aligning it in the vertical position with the arrow pointing upwards.
6. While continuing to hold retaining cable, slide the Fast-Fit sealing washer and the fluidiser washer over the retaining cable and onto the stem. Next slide the nut over the retaining cable and thread it onto the stem.
7. Tighten to the specified fluidiser torque of 35Nm and remove the retaining cable.

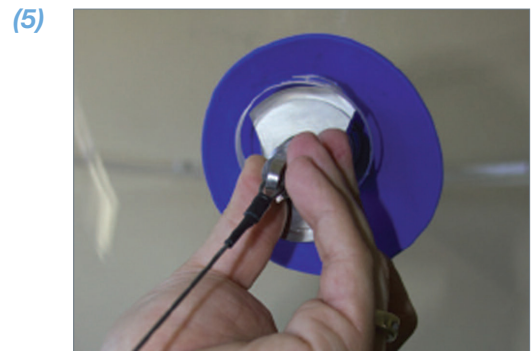

Visit - [www.prospare.co.uk](http://www.prospare.co.uk) | Call - 01773 814008 | Email - [sales@prospare.co.uk](mailto:sales@prospare.co.uk)

ProSpare Ltd. Registered in England No. 9278333  
Castlewood Business Park, Farmwell Lane, Sutton-in-Ashfield, Nottinghamshire. NG17 1BX.  
We reserve the right to modify or withdraw specifications or products without notice or obligation.  
v04062026

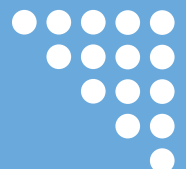

## Operating & Installation Guidelines Solimar Aeration Fluidisers



### Installation: Method 3. Easy-In Kit.

1. For the oval Easy-In Kit, the oval hole should measure 124mm high x 92mm wide. For the rectangular Easy In Kit, the rectangular hole should measure 162mm high x 67mm wide. Templates are available.
2. On conical hoppers make sure the mounting diameter at the center of the plate is greater than 600mm. Diameters of 600mm - 800mm will require a curved plate when using the oval kit.
3. Flame cut the hole as described above with cutting torch or by other means. Grind all surfaces of the cut opening – the inside of the hopper wall must be smooth and free of any burrs or slag.

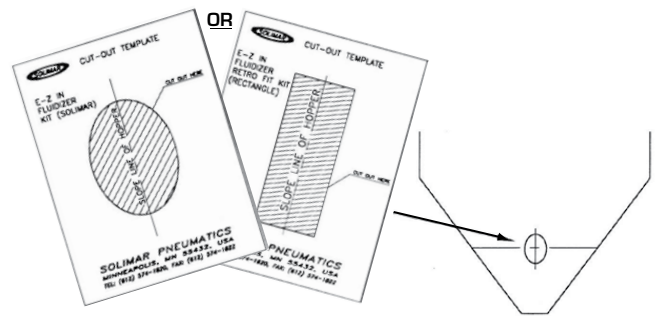

4. Attach the fluidiser assembly to the plate using the washer and thinner mounting nut.

Insert Solimar Easy-In plate with fluidiser assembly, making sure the location pin on the oval kits is resting at the bottom of the opening.

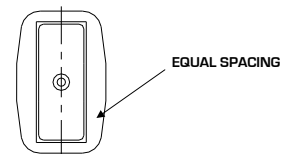
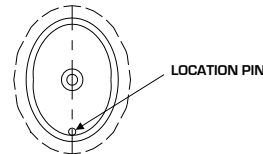

On rectangle kits, make sure the plate is centered with equal spacing around the opening.

5. On the outside of the hopper, attach cross bar to the fluidiser plate assembly with the washer & clamping nut.
6. Torque clamping nut to 27Nm.
7. Attach the air supply line to the fluidiser.

