

# ProSpare

Make it better.

## DataSheet Solimar Aeration Fluidiser



Solimar Fluidisers are widely recognised as the most effective means of solving powder flow problems. The fluidiser principle was first developed by Solimar and is now accepted as one of the most efficient means of creating the uniform flow of dry bulk materials. A powerful combination of aeration, directional airflow and gentle vibration prevent bridging, ratholing and compacting.

Solimar Fluidisers create twice as much aeration action as many lookalikes. Unique design features produce minimum back pressure and generate unrestricted airflow, offering a more efficient and cost effective solution.

Powder flow characteristics and vessel design vary tremendously. That's why we offer the widest combination of disks and stems, including the Mini Disk for small vessels. Selecting the right fluidiser helps minimise air consumption and energy costs whilst creating faster and more reliable powder discharge. Speak to the specialists for a tailored solution.

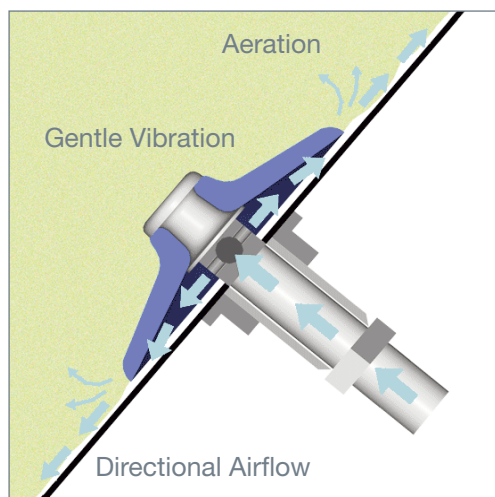

**More aeration action**

**Eliminates backflow & airline clogging**

**Less air, lower running costs**

**Fewer needed per vessel**

**FDA approved food grade disks with stainless steel stems \***

**Mini disk option available**

Unique Silicone Material



Fluidiser disk will not harden, crack or tear. More durable for longer life.

Radial Ridge Design

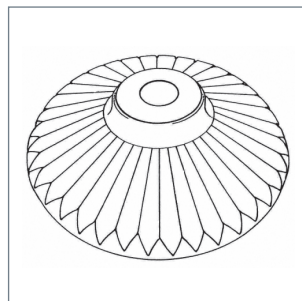

Insist on genuine Solimar disks with the trademarked radial ridge design.

Unrestricted Air Flow

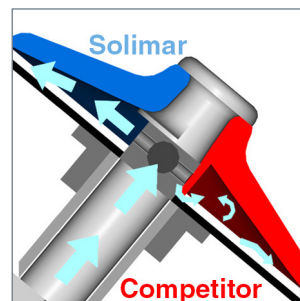

Up to 130% more effective than designs which cover air distribution ports.

Fast-Fit Kits

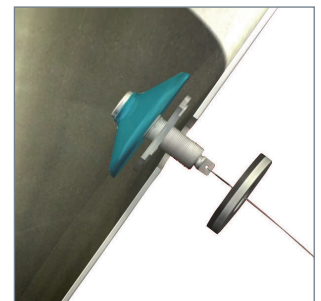

Fast-fit mounting kits allow safer installation and access from outside the silo.

Visit - [www.prospare.co.uk](http://www.prospare.co.uk) | Call - 01773 814008 | Email - [sales@prospare.co.uk](mailto:sales@prospare.co.uk)

ProSpare Ltd. Registered in England No. 9278333  
Castlewood Business Park, Farmwell Lane, Sutton-in-Ashfield, Nottinghamshire. NG17 1BX.

We reserve the right to modify or withdraw specifications or products without notice or obligation.  
ProSpare makes no warranty of any kind, expressed or implied, except that goods sold shall be of merchantable quality, free of manufacturing defect.  
The buyer assumes all risk and liability resulting from the use of the goods and it is their responsibility to determine suitability and regulatory compliance for any specific application.

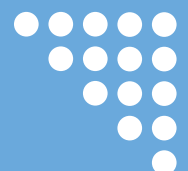

# The Solimar Principle

Solimar Fluidisers are used in 66 countries and have proven successful in solving flow problems with over 125 dry bulk materials, using the tried and tested Solimar technique:

**Directional Air Flow.** Air is forced between chamber wall and product, creating a 360° 'air-sweep', reducing friction and creating an 'avalanche' effect.

**Aeration** loosens up the product allowing it to flow. Minimum back pressure puts air energy where it is needed the most – into the product chamber.

**Gentle Vibration** keeps the product flowing, preventing compaction or plugging.

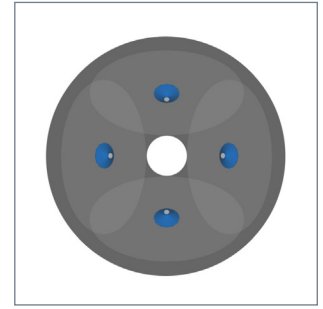

Overlapping air-sweeps make cone live

## Technical Data

4300 Series: High Pressure / Low Vol.			
Model	Stock No	Disk	Stem
4300	031180	Blue	Mild Steel
4300 HT	034004	Orange	Mild Steel
4301	031181	White	Mild Steel
4323	042505	Black EPDM	Mild Steel
4302	031182	Blue	Aluminium
4303	031183	White	Aluminium
* 4304	031184	Blue	Stainless
* 4305	031185	White	Stainless
* 4307 B	034003	Black EPDM	Stainless
* 4307 W	034005	White EPDM	Stainless
4305 HT	042504	Orange	Stainless
* 4305 MD	035551	Grey	Stainless

4400 Series: High Pressure / High Vol.			
Model	Stock No	Disk	Stem
4400	031186	Blue	Mild Steel
4401	031187	White	Mild Steel
4407	042507	Black EPDM	Mild Steel
4402	031188	Blue	Aluminium
4403	031189	White	Aluminium
* 4404	031190	Blue	Stainless
* 4405	031191	White	Stainless
* 4406	042508	Black EPDM	Stainless
4405 HT	042509	Orange	Stainless

4500 Series: Low Pressure / High Vol.			
Model	Stock No	Disk	Stem
4500	031192	Blue	Mild Steel
4501	031193	White	Mild Steel
4502	031194	Blue	Aluminium
4503	031195	White	Aluminium
* 4504	031196	Blue	Stainless
* 4505	031197	White	Stainless
4505 HT	035436	Orange	Stainless

4800 Series: Mini Disk			
Model	Stock No	Disk	Stem
* 4804	034847	Blue	Stainless
* 4805	042083	White	Stainless

\* FDA approved food grade disks with stainless steel stems  
 Standard model blue or white disks - maximum operating temperature 170°C.  
 HT = High Temperature - maximum operating temperature 230°C.  
 All disks are a silicone based material unless otherwise stated  
 316 stainless stem options available on request.

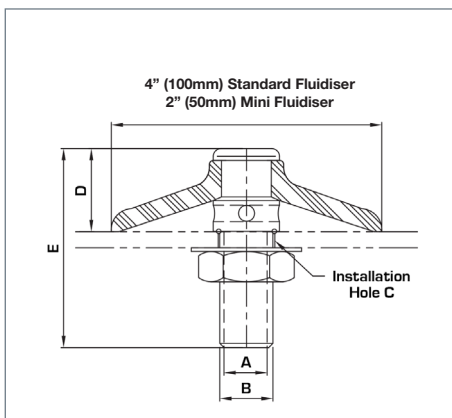

Series	A (NPT)	B (NPT)	C	D	E	Airline Options
4300	¼"	½"	22mm	30mm	76mm	10mm - 12mm
4400	½"	¾"	27mm	32mm	78mm	13mm - 19mm
4500	¾"	1"	35mm	32mm	83mm	19mm - 25mm
4800	1/8"	N/A	13mm	14mm	38mm	6mm

Series	Airflow Requirements
4300	Capacity 10 - 20 CFM @ 20 - 30 PSI (15 - 30 m³/h @ 1 - 2 bar)
4400	Capacity 25 - 40 CFM @ 10 - 20 PSI (40 - 70 m³/h @ 0.7 - 1.5 bar)
4500	Capacity 30 - 50 CFM @ 5 - 10 PSI (50 - 85 m³/h @ 0.3 - 0.7 bar)
4800	Capacity 2 - 3 CFM @ 20 - 30 PSI (3.5 - 5 m³/h @ 1 - 2 bar)

Visit - [www.prospare.co.uk](http://www.prospare.co.uk) | Call - 01773 814008 | Email - [sales@prospare.co.uk](mailto:sales@prospare.co.uk)

ProSpare Ltd. Registered in England No. 9278333  
 Castlewood Business Park, Farmwell Lane, Sutton-in-Ashfield, Nottinghamshire. NG17 1BX.

We reserve the right to modify or withdraw specifications or products without notice or obligation.  
 ProSpare makes no warranty of any kind, expressed or implied, except that goods sold shall be of merchantable quality, free of manufacturing defect.  
 The buyer assumes all risk and liability resulting from the use of the goods and it is their responsibility to determine suitability and regulatory compliance for any specific application.

