

DataSheet

ProSpare

Pneumatic Impacting Vibrator - V1

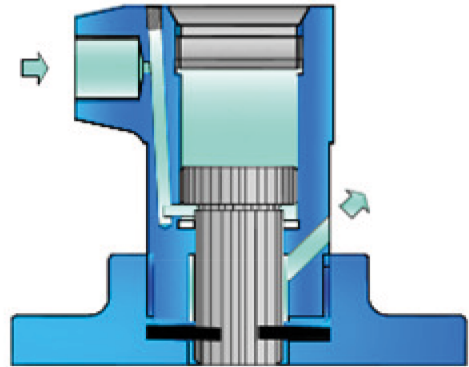

- Linear Vibration
- Robust Unit
- Steel Forged Body
- Nitride Hardened Steel Piston

On request can be supplied with ATEX certification to ATEX 2014/34/EU  II 2 G & D Zone 1, 2 & 21, 22

DIMENSIONS

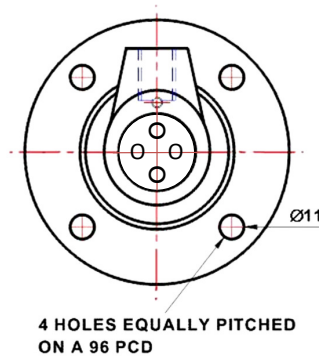
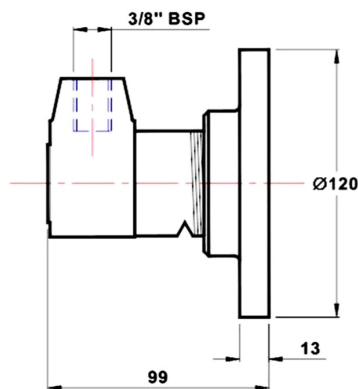

Drawing No 044139.2

PERFORMANCE DATA

MODEL	Piston Dia. mm	Stroke mm	Height mm	Fixing Bolts	Impacts per/min	Air Consumption litres/min	Working Pressure	Weight kgs
V1	28.5	25.4	99	M10	4000	160	6 Bar	2.04

ProSpare

Bestwood Road • Pinxton • Nottinghamshire NG16 6NT
Tel • +44 (0)1773 814008 • Fax • +44 (0)1773 860055 • Email • sales@prospare.co.uk

prospare.co.uk

We reserve the right to modify or withdraw specifications or products without notice or obligation.