

DataSheet

ProSpare

Linear Impacting Vibrator - BV

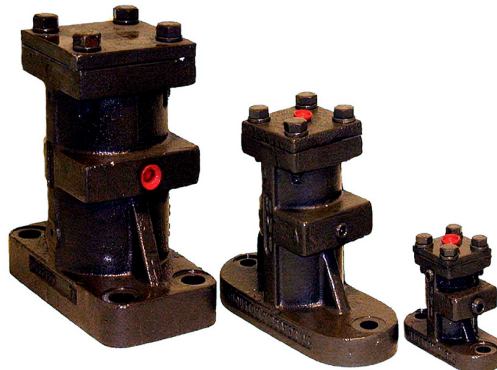

- Linear Vibrator
- Continuous running or single impact
- Force 330 N to 26050 N
- Suitable for temperature up to 80°C

DIMENSIONS

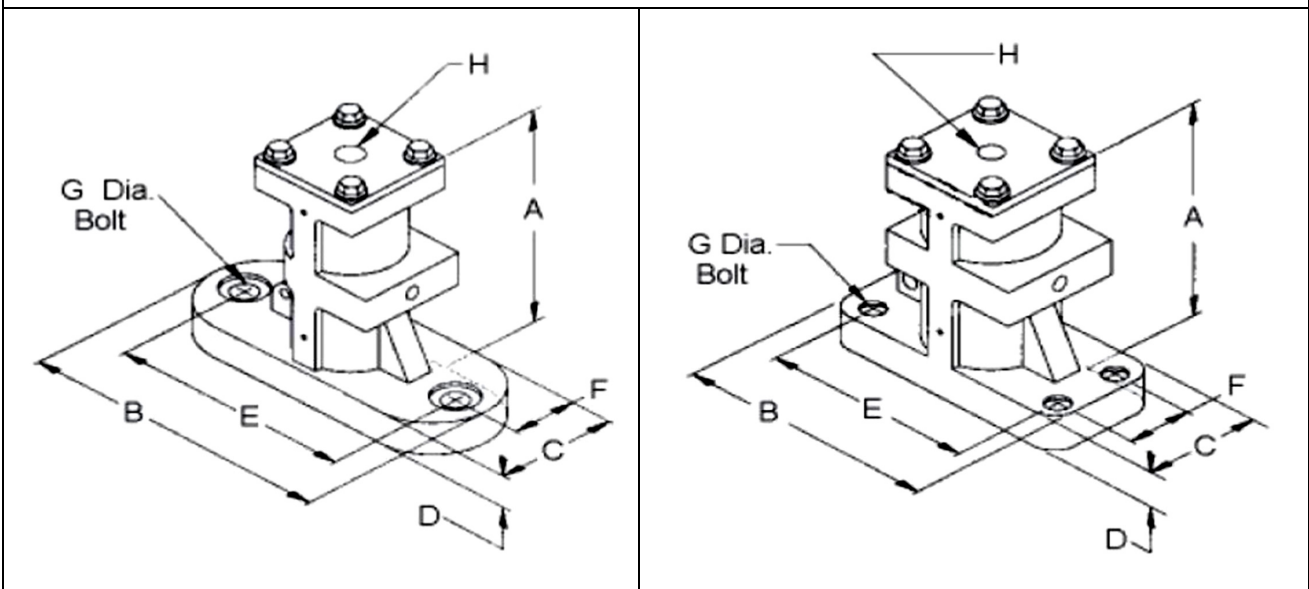

Models BV 112, 150 and 225

Models BV 312, 425 and 650

MODEL	A mm	B mm	C mm	D mm	E mm	F mm	G mm	H BSP	Piston Diameter mm	Weight Kgs	Hopper Wall mm	Capacity in Sloping Section
BV 112	95.25	114.3	50.8	12.7	88.9	25.4	12.7	1/4"	28	1.8	1.5 - 3.0	0.15 m ³
BV 150	139.7	152.4	63.5	19.0	114.3	31.7	12.7	1/4"	38	4.1	1.5 - 3.0	0.4 m ³
BV 225	184.1	228.6	88.9	25.4	190.5	44.4	15.8	1/4"	57	9.5	4.0 - 6.0	1.7 m ³
BV 312	241.3	241.3	127.0	34.9	196.8	82.5	22.2	3/8"	80	24.0	6.0 - 10.0	8 m ³
BV 425	304.8	355.6	152.6	38.1	304.8	101.6	25.4	1/2"	108	44.4	10.0 - 12.5	35 m ³
BV 650	508.0	355.6	254.0	50.8	279.4	177.8	38.1	1/2"	165	176.0	10.0 & Up	200 m ³

PERFORMANCE DATA

SINGLE IMPACTING FORCE

MODEL	2 Bar		4 Bar		6 Bar	
	kgs/m	n/m	kgs/m	n/m	kgs/m	n/m
BV 112	0.15	1.47	0.29	2.84	0.44	4.31
BV 150	0.69	6.77	1.38	13.53	2.08	20.40
BV 225	0.97	9.51	4.01	9.81	5.98	58.64
BV 312	5.67	55.60	11.35	111.40	16.88	165.54
BV 425	21.18	207.71	42.21	413.94	62.00	608.12
BV 650	29.89	293.31	59.79	586.34	89.68	879.46

CONTINUOUS IMPACTING

MODEL	2 Bar (30 PSI)				4 Bar (60 PSI)				6 Bar (88 PSI)			
	Force kgs	Force kN	Freq. RPM	Air L/ min	Force kgs	Force kN	Freq. RPM	Air L/ min	Force kgs	Force kN	Freq. RPM	Air L/ min
BV 112	33.1	325	4450	26	62.1	609	6200	57	97.5	956	7850	126
BV 150	62.1	609	3175	52	128	1255	4600	98	182	1784	5500	166
BV 225	144	1412	2800	115	235	2304	3600	172	318	3118	4200	207
BV 312	314	3079	2175	215	546	5354	2900	301	787	7718	3500	344
BV 425	474	4648	1525	221	759	7443	1950	373	1137	11150	2400	451
BV 650	1319	12935	975	708	2818	27635	1425	1584	4525	44375	1875	2605

Kgs/m = Kilo Force.metre, n/m = newton.metre

Typical Installation Air-Schematic

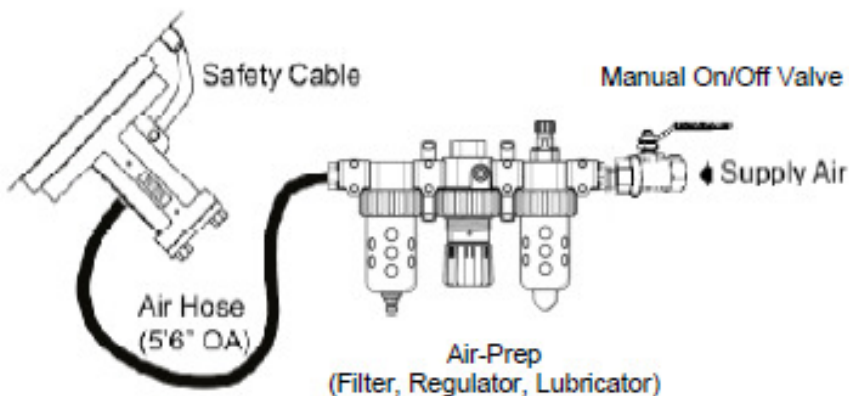

IMPORTANT
It is recommended that a 3/2 Pneumatic Valve is used in installation. Leaflet L1103 Available on request

ProSpare

Bestwood Road • Pinxton • Nottinghamshire NG16 6NT
Tel • +44 (0)1773 814008 • Fax • +44 (0)1773 860055 • Email • sales@prospare.co.uk

prospare.co.uk

We reserve the right to modify or withdraw specifications or products without notice or obligation.