

DataSheet

ProSpare

Pneumatic Linear Vibrator - FPLF Lubrication Free In Operation

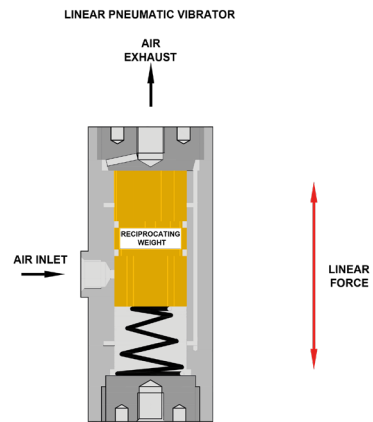

Models FPLF12 - FPLF35

- Linear Vibration
- Ideal for arduous conditions
- Force 22 N to 1066 N
- Frequency and amplitude adjustable independently
- Suitable for ambient temperature from 10°C up to 120°C
- FPLF LT low temperature and FPLF HT high temperature Vibrators are also available
- Aluminium construction, extra hard and corrosion resistant with electropolished surface finish
- Compliant with FDA specifications and therefore ideal for food, beverage and pharmaceutical applications
- Suitable for Dry Air, the piston is pre lubricated during the manufacturing process
- Relubrication of piston is necessary periodically with Klubersynth UHI.14.31
- Stud Fixing

On request can be supplied with ATEX certification to ATEX 2014/34/EU  II 2 G & D Zone 1, 2 & 21, 22

FPLF12-35 PERFORMANCE DATA

Models	Frequency V.P.M.			Linear Force Measured						Air Consumption / Minute						Noise Level	
	2 Bar 29PSI	4 Bar 58PSI	6 Bar 87PSI	2Bar N	29PSI lbs	4Bar N	58PSI lbs	6Bar N	87PSI lbs	2Bar litr	29PSI CFM	4Bar litr	58PSI CFM	6 Bar litr	87PSI CFM	A** dB	A*** dB
FPLF-12-XS	6000	9000	11500	22	4.8	48	10.6	68	15	0.8	0.03	6	0.21	15	0.53	60-64	N/A
FPLF-12-S	6200	7800	9300	34	7.7	70	16	92	21	0.8	0.03	7.5	0.26	25	0.88	57-61	N/A
FPLF-12-M	5000	6000	6700	34	7.7	58	13	74	17	0.5	0.02	4	0.14	19	0.67	57-61	N/A
FPLF-12-L	4000	4800	5400	32	7.2	58	13	81	18	1	0.04	3	0.11	20	0.71	58-60	N/A
FPLF-18-S	5000	6400	7700	66	15.0	134	30	187	42	5	0.18	33	1.16	57	2.00	62-71	N/A
FPLF-18-M	4000	5000	5900	68	15.0	134	30	188	42	4	0.14	28	1.00	52	1.84	61-67	N/A
FPLF-18-L	3100	4000	4600	64	14.0	150	34	206	46	5	0.18	23	0.81	46	1.62	61-68	N/A
FPLF-25-S	3600	4300	5500	126	28	270	61	416	94	13	0.46	54	1.91	93	3.28	70-75	61-67
FPLF-25-M	3000	3800	4200	142	32	364	82	504	113	23	0.81	50	1.76	87	3.07	73-75	62-66
FPLF-25-L	2400	3100	3700	186	42	392	88	594	134	18	0.64	62	2.19	93	3.28	72-75	60-65
FPLF-35-S	3800	4700	5800	294	66	668	150	1038	234	23	0.81	101	3.56	162	5.72	72-77	71-73
FPLF-35-M	3000	4000	4600	248	56	778	175	1080	243	24	0.84	83	2.93	141	4.98	74-78	70-73
FPLF-35-L	2400	3100	3600	282	63	680	153	1066	240	38	1.34	89	3.14	135	4.77	74-78	68-74

NOISE LEVEL NOTE ** With customary silencer *** With 1/4" Free Flow Silencer

FREQUENCY AND AMPLITUDE: By using a flow restricting silencer on the FP, FPLF, FAL, and VTL vibrators the amplitude can be reduced whilst the frequency remains almost constant.

FPLF12-FPLF35 DIMENSIONS Stud Fixing



Stud Fixing

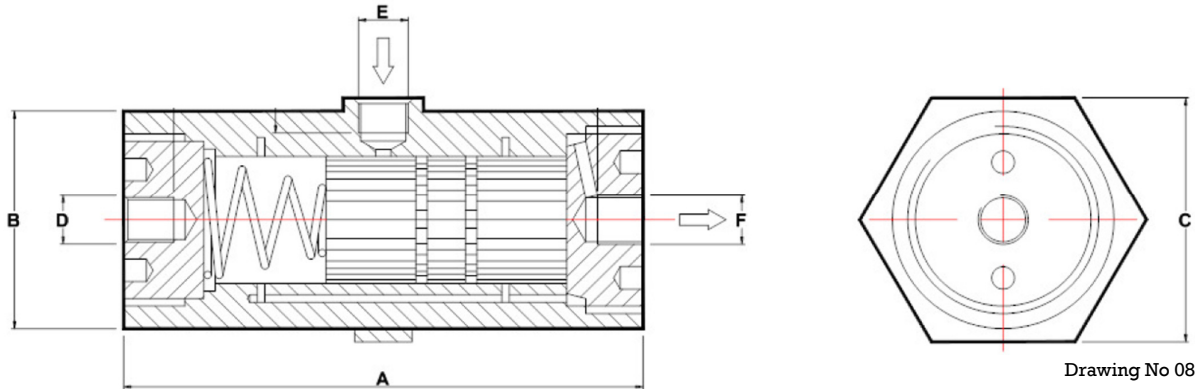

Drawing No 082001

Models	A		B		C		D Metric	BSP Thread		Weight of Body		Weight of Piston		Total Weight		
	Standard	mm	inch	mm	inch	mm		inch	E	F	kg	lbs	kg	lbs	kg	lbs
FPLF-12-XS		50	1.97	31	1.22	37	1.34	M8	1/8"	1/8"	0.092	0.202	0.013	0.029	0.105	0.231
FPLF-12-S		71	2.80	31	1.22	34	1.34	M8	1/8"	1/8"	0.125	0.275	0.020	0.045	0.145	0.320
FPLF-12-M		81	3.19	31	1.22	34	1.34	M8	1/8"	1/8"	0.140	0.309	0.030	0.066	0.170	0.375
FPLF-12-L		94	3.70	31	1.22	34	1.34	M8	1/8"	1/8"	0.165	0.360	0.040	0.090	0.205	0.450
FPLF-18-S		81	3.19	40	1.57	42	1.65	M10	1/8"	1/8"	0.220	0.485	0.060	0.135	0.300	0.660
FPLF-18-M		94	3.70	40	1.57	42	1.65	M10	1/8"	1/8"	0.260	0.575	0.080	0.175	0.350	0.770
FPLF-18-L		109	4.29	40	1.57	42	1.65	M10	1/8"	1/8"	0.300	0.660	0.110	0.240	0.420	0.924
FPLF-25-S		98	3.86	48	1.89	50	1.97	M12	1/8"	1/4"	0.375	0.825	0.155	0.345	0.550	1.210
FPLF-25-M		116	4.57	48	1.89	50	1.97	M12	1/8"	1/4"	0.435	0.955	0.215	0.475	0.670	1.474
FPLF-25-L		136	5.35	48	1.89	50	1.97	M12	1/8"	1/4"	0.500	1.100	0.290	0.640	0.820	1.804
FPLF-35-S		98	3.86	58	2.28	65	2.55	M12	1/4"	1/4"	0.530	1.168	0.315	0.694	0.930	2.046
FPLF-35-M		116	4.57	58	2.28	65	2.55	M12	1/4"	1/4"	0.610	1.344	0.430	0.947	1.130	2.486
FPLF-35-L		136	5.35	58	2.28	65	2.55	M12	1/4"	1/4"	0.700	1.543	0.530	1.278	1.380	3.036

FPLF35 with square baseplate



The FPLF35 range are available with a square baseplate 90 x90 x 20mm thick, with 9mm fixing holes on 72mm centres.

The plate part number 99035.80 is supplied with 12mm fixing screws to secure the baseplate to the FP Vibrator. The baseplate is ordered separately to the Vibrator

IMPORTANT

It is recommended that a 3/2 Pneumatic Valve is used in installation.
Leaflet L1103 Available on request







Models FPLF50 - FPLF95

- Linear Vibration
- Aluminium construction, extra hard and corrosion resistant with electropolished surface finish
- Compliant with FDA specifications and therefore ideal for food, beverage and pharmaceutical applications
- Ideal for arduous conditions
- Force 34 N to 1066 N
- Frequency and amplitude adjustable independently
- Amplitude and Frequency can be adjusted by using the different ports
- Suitable for ambient temperature from 10°C up to 120°C .
- FPLF LT low temperature and FPLF HT high temperature vibrators are also available
- Suitable for Dry Air, the piston is pre lubricated during the manufacturing process
- Relubrication of piston is necessary periodically with Klubersynth UHI.14.31



On request can be supplied with ATEX certification to ATEX 2014/34/EU  II 2 G & D Zone 1, 2 & 21, 22

FPLF50-95 PERFORMANCE DATA with square baseplates (See also Data sheet L1012.1)																			
<p>FPLF 50and 60 are supplied with countersunk screws to blank off ports not used. Supplied as build 1 unless otherwise requested.</p> <p>FPLF 95 does not have a top port, supplied as build 4 unless other wise requested.</p>																			
		Build 1			Build 2			Build 3			Build 4								
Model	Build	Frequency V.P.M.			Linear Force Measured						Air Consumption / Minute						Noise Level dBA		
		2 Bar 29PSI	4 Bar 58PSI	6 Bar 87PSI	2Bar N	29PSI lbs	4Bar N	58PSI lbs	6Bar N	87PSI lbs	2Bar litr	29PSI CFM	4Bar litr	58PSI CFM	6 Bar litr	87PSI CFM			
FPLF-50-M	Build 1	1850	2300	2800	490	110	970	218	1600	360	48	1.67	100	3.48	190	6.61	70-77		
FPLF-60-M		1950	2400	2700	610	137	1400	315	2170	489	90	3.13	160	5.57	270	9.39	73-79		
FPLF-50-M	Build 2	1850	2300	2800	470	107	1020	230	1950	438	78	2.75			280	9.89	76-83		
FPLF-60-M		1950	2400	2700	670	151	1450	326	2400	540	115	4.06			335	11.83	75-82		
FPLF-50-M	Build 3	1850	2300	2800	460	103	980	220	1850	416	78	2.75			280	9.88	80-87		
FPLF-60-M		1950	2400	2700	610	137	1450	326	2200	495	115	4.06			335	11.93	78-84		
FPLF-95-M		1800	2400	2800	1500	338	2620	590	4270	962	170	5.91	320	11.13	450	15.65	85-92		
FPLF-50-M	Build 4	1850	2300	2800	450	101	1000	225	1900	427	78	2.75			310	10.95	86-92		
FPLF-60-M		1950	2400	2700	630	142	1440	324	2300	517	115	4.06			335	11.83	84-90		
FPLF-95-M	Build 4	1800	2400	2800	1620	364	4060	913	6150	1382	170	5.91			490	17.30	86-93		

FPLF50-FPLF95 DIMENSIONS FPLF50-FPLF95 with square baseplates

FPLF-50 und 60

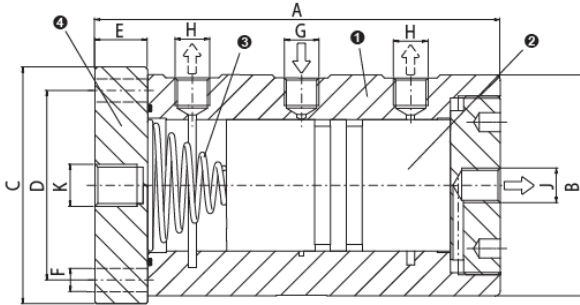

FPLF-95

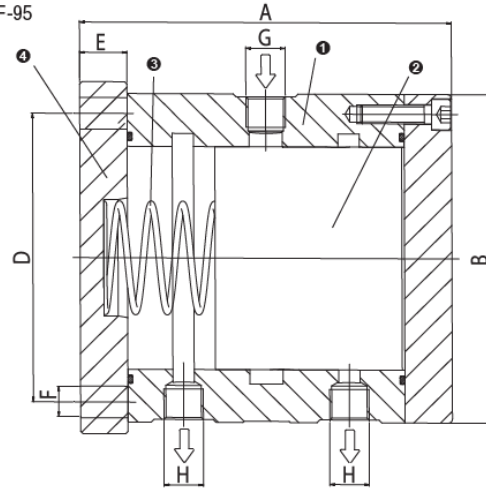

- 1 Housing made from hard anodized aluminium alloy
- 2 Piston made from leaded bronze
- 3 Steel spring
- 4 End Cap made from hard anodized aluminium

Models	A		B Ø		C		D		E		F		BSP Thread		
	mm	inch	mm	inch	mm	inch	mm	inch	mm	inch	mm	inch	G	H	J
FPLF-50-M	154	6.07	84	3.31	90	3.54	72	2.84	20	0.78	8.8	0.35	1/4"	1/4"	1/4"
FPLF-60-M	154	6.07	94	3.70	110	4.33	90	3.54	20	0.78	8.8	0.35	1/4"	3/8"	1/4"
FPLF-95-M	156	6.15	140	5.52	150	5.90	125	4.92	20	0.78	13.0	0.52	3/8"	3/8"	N/A
	Weight of Body				Weight of Piston				Total Weight						
	kg		lbs		kg		lbs		kg		lbs				
FPLF-50-M	1.750		3.858		1.500		3.307		3.05		6.71				
FPLF-60-M	2.100		4.629		2.150		4.740		4.10		9.02				
FPLF-95-M	4.500		9.921		4.900		10.802		8.75		19.25				

IMPORTANT

It is recommended that a 3/2 Pneumatic Valve is used in installation. Leaflet L1103 Available on request



	<p>The FPLF and FAL Pneumatic Vibrator should be dismantled periodically and the piston regreased with Klüber Grease UHI.14.31 This is available in a small tub part number 046757</p> <p>Service Data Sheet M1120</p>
<p>Klüber Grease Leaflet L1120</p>	

ProSpare

Bestwood Road • Pinxton • Nottinghamshire NG16 6NT
 Tel • +44 (0)1773 814008 • Fax • +44 (0)1773 860055 • Email • sales@prospare.co.uk

prospare.co.uk