

# DataSheet

## CAMS Screw Conveyors

# ProSpare

CAMS screw conveyors incorporate unique patented technology to ensure more reliable operation for trouble free cost effective performance. The introduction of labyrinth protected hanger bearings and screw flight connections is a major step forward in screw conveyor design. Labyrinth protected hanger bearings offer extended service life resulting in less maintenance, lower running costs and safer operation. CAMS screw conveyors are supported in the field by our market leading technical support and spare parts service.

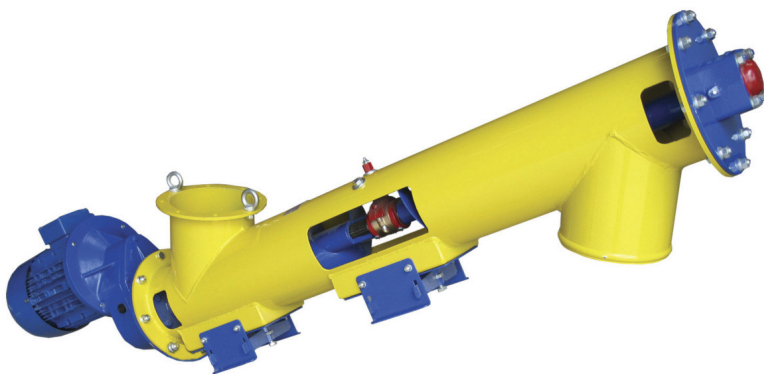

**Patented labyrinth protection**

**Reliable operation**

**Lower whole life cost**

**Ex-stock availability**

**Free design service**

In response to customer demand ProSpare stock a wide range of screw conveyors in common sizes, see overleaf for details. The screw conveyor application questionnaire is available to help simplify the specification process, clearly setting out data requirements, to allow a quotation to be prepared. We supply a wide range of ancillary components and offer a one stop solution for all your powder handling needs.

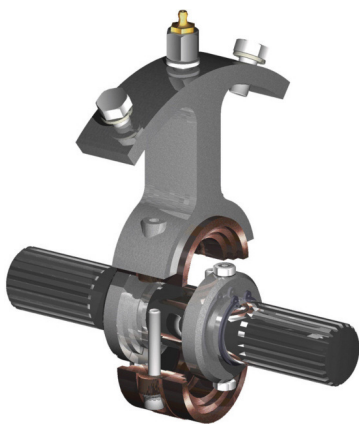

New labyrinth protected hanger bearing for longer service life

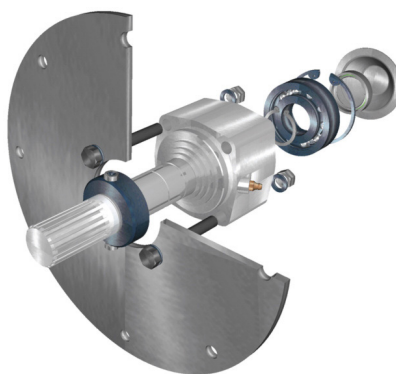

Engineered for maximum accessibility and user friendly maintenance

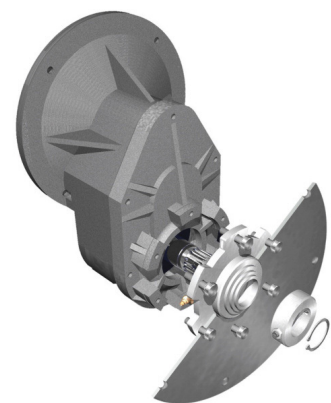

Gearboxes manufactured in-house to ensure highest levels of reliability



Sole Agent in  
UK and Ireland

# CAMS SCREW CONVEYORS FROM STOCK

DIMENSIONAL CENTRES			0	5000	5600	6000	6600	7000	7400	8000	9000	9600	10,000	10,400	11,000	12,000
STOCK NUMBER	219 DIA	273 DIA	R.P.M													
PX920000	PX920002	PX920003	200	2750	2750	2750	2750	2750	2750	2750	2750	2750	2750	2750	2750	2750
PX920001	PX920003	PX920003	300	2750	2750	2750	2750	2750	2750	2750	2750	2750	2750	2750	2750	2750
PX920004	PX920006	PX920007	200	2750	2750	2750	2750	2750	2750	2750	2750	2750	2750	2750	2750	2750
PX920005	PX920007	PX920007	300	2750	2750	2750	2750	2750	2750	2750	2750	2750	2750	2750	2750	2750
PX920008	PX920010	PX920011	200	2750	2750	2750	2750	2750	2750	2750	2750	2750	2750	2750	2750	2750
PX920009	PX920011	PX920011	300	2750	2750	2750	2750	2750	2750	2750	2750	2750	2750	2750	2750	2750
PX920012	PX920014	PX920015	200	2750	2750	2750	2750	2750	2750	2750	2750	2750	2750	2750	2750	2750
PX920013	PX920015	PX920015	300	2750	2750	2750	2750	2750	2750	2750	2750	2750	2750	2750	2750	2750
PX920016	PX920018	PX920019	200	2750	2750	2750	2750	2750	2750	2750	2750	2750	2750	2750	2750	2750
PX920017	PX920019	PX920019	300	2750	2750	2750	2750	2750	2750	2750	2750	2750	2750	2750	2750	2750
PX920020	PX920022	PX920023	200	2750	2750	2750	2750	2750	2750	2750	2750	2750	2750	2750	2750	2750
PX920021	PX920023	PX920023	300	2750	2750	2750	2750	2750	2750	2750	2750	2750	2750	2750	2750	2750
PX920024	PX920026	PX920027	200	2750	2750	2750	2750	2750	2750	2750	2750	2750	2750	2750	2750	2750
PX920025	PX920027	PX920027	300	2750	2750	2750	2750	2750	2750	2750	2750	2750	2750	2750	2750	2750
PX920028	PX920030	PX920031	200	2750	2750	2750	2750	2750	2750	2750	2750	2750	2750	2750	2750	2750
PX920029	PX920031	PX920031	300	2750	2750	2750	2750	2750	2750	2750	2750	2750	2750	2750	2750	2750
PX920032	PX920034	PX920035	200	2750	2750	2750	2750	2750	2750	2750	2750	2750	2750	2750	2750	2750
PX920033	PX920035	PX920035	300	2750	2750	2750	2750	2750	2750	2750	2750	2750	2750	2750	2750	2750
PX920036	PX920038	PX920039	200	2750	2750	2750	2750	2750	2750	2750	2750	2750	2750	2750	2750	2750
PX920037	PX920039	PX920039	300	2750	2750	2750	2750	2750	2750	2750	2750	2750	2750	2750	2750	2750
PX920040	PX920042	PX920043	200	2750	2750	2750	2750	2750	2750	2750	2750	2750	2750	2750	2750	2750
PX920041	PX920043	PX920043	300	2750	2750	2750	2750	2750	2750	2750	2750	2750	2750	2750	2750	2750
PX920044	PX920046	PX920047	200	2750	2750	2750	2750	2750	2750	2750	2750	2750	2750	2750	2750	2750
PX920045	PX920047	PX920047	300	2750	2750	2750	2750	2750	2750	2750	2750	2750	2750	2750	2750	2750
PX920048	PX920050	PX920051	200	2750	2750	2750	2750	2750	2750	2750	2750	2750	2750	2750	2750	2750
PX920049	PX920051	PX920051	300	2750	2750	2750	2750	2750	2750	2750	2750	2750	2750	2750	2750	2750

Foregoing lengths indicative only. Stock availability subject to prior sale. Subject to change without prior notice.

**ProSpare**

Bestwood Road • Pinxton • Nottinghamshire NG16 6NT  
 Tel • +44 (0)1773 814008 • Fax • +44 (0)1773 860055 • Email • sales@prospare.co.uk

[prospare.co.uk](http://prospare.co.uk)

We reserve the right to modify or withdraw specifications or products without notice or obligation.